



... siente la luz

Póligono Industrial los Vientos - Calle Aliso, parcela nº4 - 46119, Náquera, Valencia, SPAIN
T +34 96 160 99 50 - F +34 96 160 99 48 - mantra@mantraco.org - www.mantrailuminación.com

ANEXO

www.mantrailuminacion.com

mantra



mantra

Philosophy

“... Siente la luz”, es la frase que viste y acompaña nuestra imagen desde el nacimiento de MANTRA.

“... Siente la luz, transmite la “filosofía” que pretendemos inspirar con nuestra forma de hacer. Los elementos de las colecciones además de iluminar, aportan sencillez y belleza, sin caer en la ostentación o lo vulgar.

Lámparas y auxiliares presentan una depuración de líneas y cierta personalidad, otorgándoles un toque sutil diferenciador.

Por eso confiamos en el buen hacer... la profesional labor de nuestros diseñadores y en nuestro criterio a la hora de crear y seleccionar objetos de iluminación que aporten personalidad, carácter y que a su vez alumbren de forma eficaz y efectiva sus espacios de una manera especial.

“... Siente la luz... siente MANTRA”.

“... Feel the light” is a phrase which has decorated and accompanied our image since the founding of MANTRA.

“... Feel the light” transmits the “philosophy” which we aim to inspire with our way of working. The elements of the collections not only provide lighting but they also decorate with elegant simplicity and beauty without excess ostentation or gaudy style.

Lamps and accessories provide graceful streamlined designs with a special personality, which give them a subtle differentiating touch.

Consequently, we trust in the craftsmanship... the professional work standards of our designers and our criteria when creating and selecting lighting products which provide distinctive personality and character as we efficiently and effectively light up your spaces with a special style.

“... Feel the Light... Feel MANTRA”.



About

MANTRA es una joven empresa que comenzó su actividad en el sector de la iluminación a mediados del año 2000. Con creación y diseño propio, ha intentado aportar una “iluminación accesible, con diseño y calidad al alcance de todos”, convirtiéndose este “lema” a partir de aquel momento en nuestro objetivo a desempeñar.

En un primer momento nuestro catálogo pretendió satisfacer el mercado español y los mercados vecinos, apostando con una amplia red de representación. Hoy podemos decir que MANTRA es conocida en gran parte del mundo al comercializar sus productos en Europa, América, Oriente Medio y Sudeste Asiático.

Confiamos en el buen hacer y la profesional labor de nuestros diseñadores y en nuestro criterio a la hora de crear y seleccionar objetos de iluminación que aporten personalidad, carácter y que a su vez alumbren de forma eficaz y efectiva sus espacios de una manera especial.

MANTRA is a young company which started its activity in the lighting industry in mid-2000. With creation and design in Spain, we tried to make an “affordable lighting, with design and quality available to everyone”, becoming this ” catchword“ in own objective.

In first time we intended satisfy our catalog Spanish market and neighboring markets, betting with a wide network representation. Today we can say that MANTRA is known in much of the world to market their products in Europe, America, Middle East and Southeast Asia.

We trust in the professional work standards of our designers and our criteria when creating and selecting lighting products which provide distinctive personality and character as we efficiently and effectively light up your spaces with a special style.

Collections



Maui	06
Sáhara	12
Triangle	18
Argenta	24
Discóbolo	30
Loewe	36
Crystal Led	44
Zero	50
Rectangle	54
Eos	58

Maui

Design

Santiago Sevillano

2014

“MAUI, una serie de lámparas colgantes con diversas personalidades: cemento, industrial y urbano; blanco neutro; o madera, absolutamente cálida. En cualquiera de estas versiones, MAUI emana sensaciones de frescura y tranquilidad que nos transportan a paisajes lejanos.

Una lámpara adaptable a diversos tipos de proyectos, gracias a sus formas esenciales y orgánicas, MAUI transmite luz tanto por su parte inferior como superior, permitiendo iluminar una mesa y el techo a la vez, funcionando así como elemento de apoyo decorativo y escultórico.”

“MAUI, hanging lamps collection with different personalities. Cement, industrial and urban; neutral white, or wood, warm in any of these versions, MAUI emanates feelings of freshness and tranquility that transport us to distant landscapes.

Adaptable lighting to various types of projects, thanks to essential and organic forms, MAUI transmits light in two directions, upward and downward, allowing light a table and the ceiling to time, functioning as decorative and sculptural element support.”







Maui

Design
Santiago Sevillano
2014

4810/4811/4812 - Colgante/Pendant Lamp

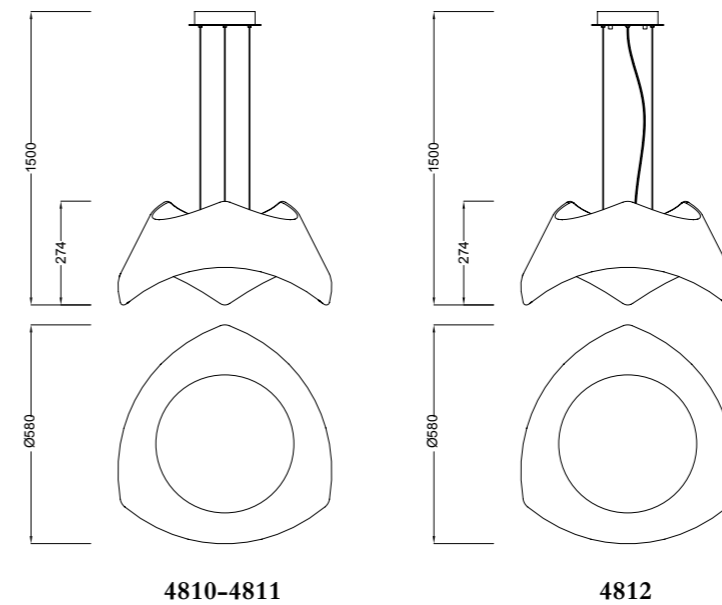

4810

- Ⓢ LED 1x25W 3000K 2520lm - 220/240V
- Arriba-Up 1x5W
- Bajo-Down 1x20W

□ Polímero blanco - White polymer

4811

- Ⓢ LED 1x25W 3000K 2520lm - 220/240V
- Arriba-Up 1x5W
- Bajo-Down 1x20W

■ Polímero Madera - Wood polymer

4812

- Ⓢ LED 1x25W 3000K 2520lm - 220/240V
- Arriba-Up 1x5W
- Bajo-Down 1x20W

■ Cemento - Cement



Sáhara

Design

Hugo Tejada

2014

Movimiento y sofisticación trasladado a un objeto iluminado. Sahara es una elegante colección inspirada en formas orgánicas, alternando dos cuerpos iluminados que generan un juego de luces y sombras sorprendente, creada para ser protagonista.

Compuesta por diversas aplicaciones y diseñada para espacios contemporáneos. En esta ocasión se ha utilizado fuente de luz Led pero llevada a su mínima expresión, un gesto iluminado con un rendimiento lumínico extraordinario que permite iluminar cualquier tipo de estancia.

Movement and sophistication projected an illuminated object. Sahara is an elegant collection inspired by organic forms, alternating two illuminated bodies that generate a amazing set of lights and shadows, created to be protagonist.

Composed of various applications and designed for contemporary spaces. This time it has been used LED light and we have applied this LED in a minimal expression, an illuminated gesture with extraordinary light output which allows to highlight any stay.



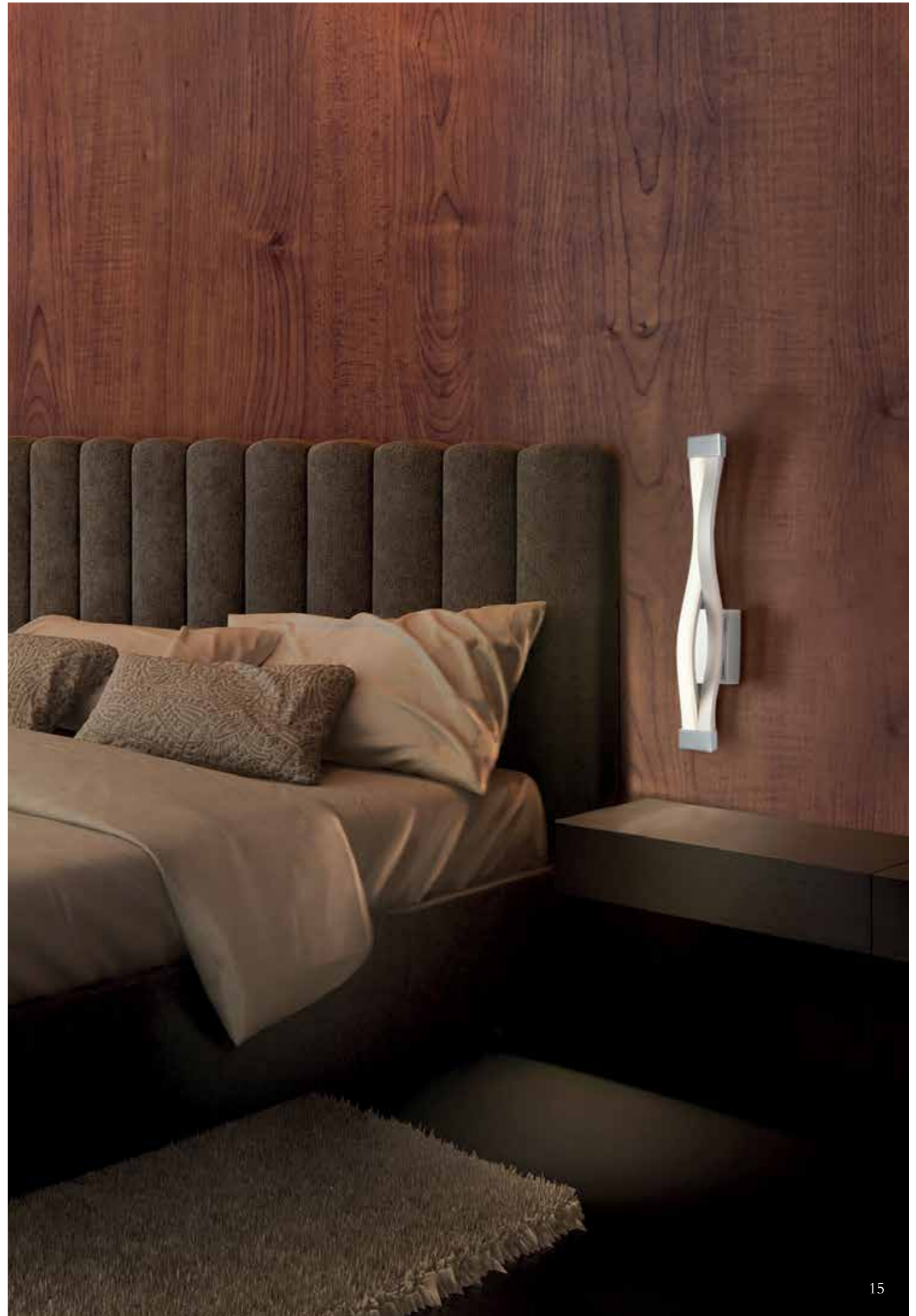



Sáhara

Design
Hugo Tejada
2014

4860 - Colgante/Pendant Lamp

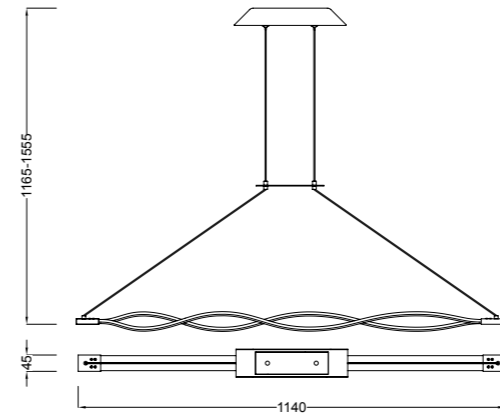

- Ⓢ LED 2x18W 3000K 2520lm - 220/240V
- Plata - Silver
- Cromo - Chrome
- ▨ Difusor Acrílico - Acrylic Diffuser



4863 - Aplique/Wall Lamp

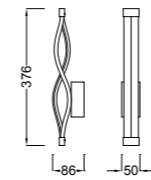

- Ⓢ LED 1x6W 3000K 540lm - 220/240V
- Plata - Silver
- Cromo - Chrome
- ▨ Difusor Acrílico - Acrylic Diffuser



4862 - Sobremesa/Table Lamp

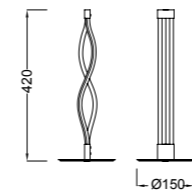

- Ⓢ LED 1x6W 3000K 540lm - 220/240V
- Plata - Silver
- Cromo - Chrome
- ▨ Difusor Acrílico - Acrylic Diffuser



4861 - Pie de Salón/Floor Lamp

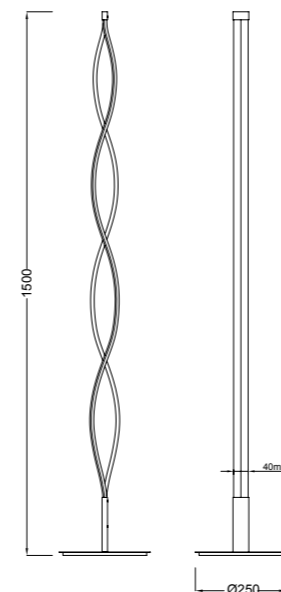

- Ⓢ LED 1x21W 3000K 1800lm - 220/240V
- Plata - Silver
- Cromo - Chrome
- ▨ Difusor Acrílico - Acrylic Diffuser



La colección TRIANGLE, del diseñador José I. Ballester, nos presenta elementos en suspensión en dos tamaños, considerablemente distintos, y en diferentes acabados. Su diseño parte de una forma circular, y en su desarrollo finaliza en una embocadura rematada por tres lados. Los colgantes de la colección se disponen en acabados madera, cálidos y acogedores; otros de aspecto más vanguardista, fabricados con cemento, y una tercera propuesta más ligera y luminosa en lacado blanco brillo. Por su versátil diseño es fácilmente adaptable a cualquier espacio del hogar, así como también a instalaciones de hostelería. Los elementos más grandes van soportados con cable de acero, y su cable de alimentación eléctrico se presenta con revestimiento textil. Alberga portalámparas E/27 en su versión más grande y E/14 en la versión más reducida.

Collection Triangle, designed by Jose I. Ballester, brings in two different sizes pendants that significantly unlike and varied finishes. Its design is formed a circular and its movement ends creating a rim with three sides. Pendants are available in three finishes: wood, cement and white lacquer. Wood finish gives you warm and welcome atmosphere, Cement finish features avant-garde and bright lacquered white creates gentle mood. This versatile design can recommend any types of rooms or any industry facilities. Large sided items are supported by steel cable, and electric power cable is covered by textile. Lamp holder is used in E 27 for big pendant, E14 for smaller.

Triangle

Design
Jose I. Ballester
2014







Triangle

Design
Jose I. Ballester
2014

4820/4821/4822 - Colgante/Pendant Lamp

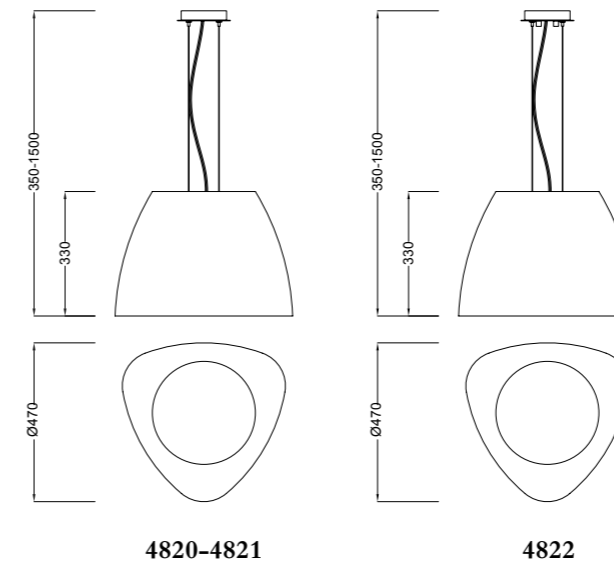

- 4820**
 E27 1x23W - 220/240V (no incl.)
 Polímero blanco - White polymer
- 4821**
 E27 1x23W - 220/240V (no incl.)
 Polímero Madera - Wood polymer
- 4822**
 E27 1x23W - 220/240V (no incl.)
 Cemento - Cement



4823/4824/4825 - Colgante/Pendant Lamp

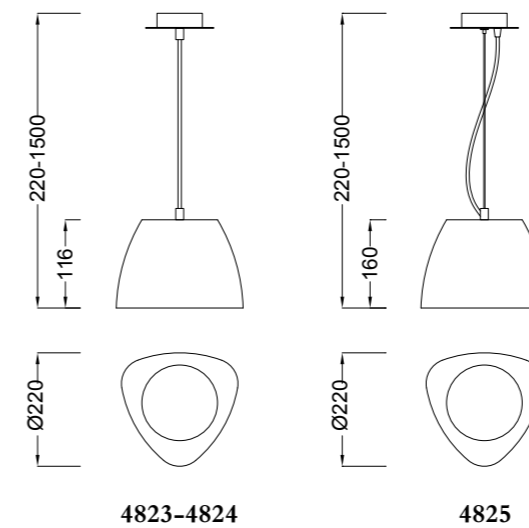

- 4823**
 E27 1x13W - 220/240V (no incl.)
 Polímero blanco - White polymer
- 4824**
 E27 1x13W - 220/240V (no incl.)
 Polímero Madera - Wood polymer
- 4825**
 E27 1x13W - 220/240V (no incl.)
 Cemento - Cement



Argenta

Design
Mantra Team
2014







Argenta

Design
Mantra Team
2014

4842/4843/4840/4841 - Colgante/Pendant Lamp

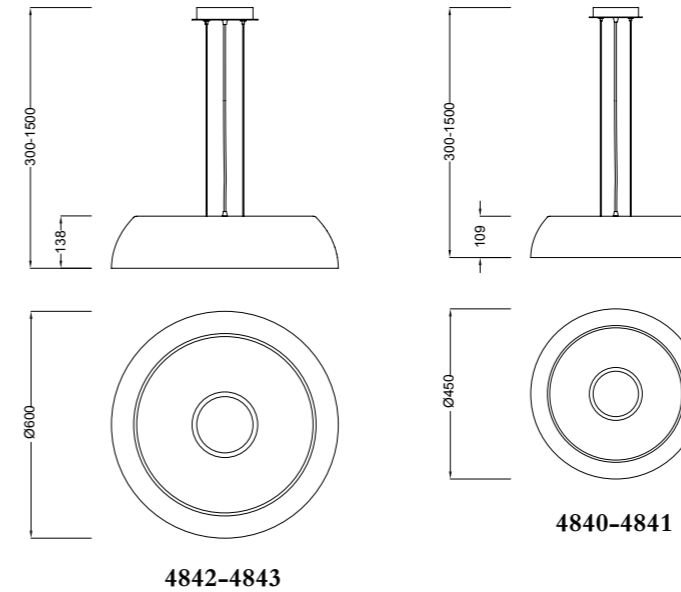

Interior plata - Silver interior

4842

LED 1x30W 3000K 3000lm - 220/240V

Metal blanco - White metal

Difusor Acrílico - Acrylic Diffuser

4843

LED 1x30W 3000K 3000lm - 220/240V

Metal negro - Black metal

Difusor Acrílico - Acrylic Diffuser

4840

LED 1x18W 3000K 2100lm - 220/240V

Metal blanco - White metal

Difusor Acrílico - Acrylic Diffuser

4841

LED 1x18W 3000K 2100lm - 220/240V

Metal negro - Black metal

Difusor Acrílico - Acrylic Diffuser

4846/4848/4847/4849 - Plafón/Ceiling Lamp

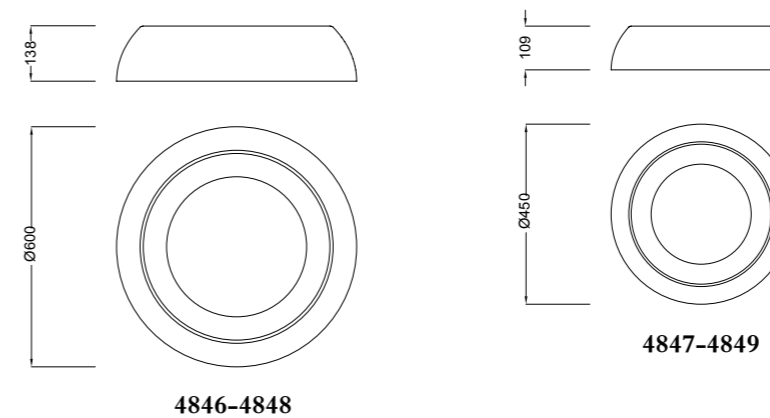

Interior plata - Silver interior

4846

LED 1x30W 3000K 3000lm - 220/240V

Metal blanco - White metal

Difusor Acrílico - Acrylic Diffuser

4848

LED 1x30W 3000K 3000lm - 220/240V

Metal negro - Black metal

Difusor Acrílico - Acrylic Diffuser

4847

LED 1x18W 3000K 2100lm - 220/240V

Metal blanco - White metal

Difusor Acrílico - Acrylic Diffuser

4849

LED 1x18W 3000K 2100lm - 220/240V

Metal negro - Black metal

Difusor Acrílico - Acrylic Diffuser

Discóbolo

Design
Hugo Tejada
2014

Pureza y simplicidad son las características principales que definirían la colección Discóbolo, lámpara de presencia, en la cual se ha combinado el diseño y el arte en su proceso de creación, utilizando tecnología LED como fuente de luz principal. Está fabricada en aluminio anodizado y acrílico de alta calidad. La colección está compuesta por diferentes aplicaciones, diseñada para ambientes contemporáneos, instalaciones y espacios contract, se trata de un producto versátil diseñado para persistir en el tiempo.

Purity and simplicity are the main characteristics that define the collection Discóbolo, presence lamp, in which combined design with art in their creative process, using LED technology as main light source. It is made of anodized aluminium and high quality acrylic. The collection consists of different applications, designed for contemporary environments, premises and contract places, it is a versatile product designed to persist a long time.





Discóbolo

Design
Hugo Tejada
2014



4490/4493/4082 - Colgante/Pendant Lamp

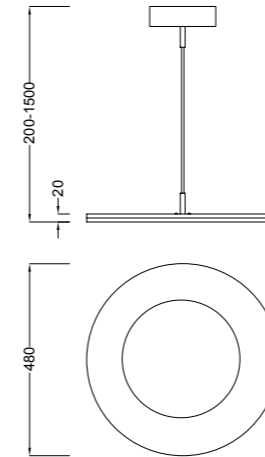

4490

LED 1x36W 3000K 3240lm - 220/240V

Metal madera - Wood metal

Difusor acrílico - Acrylic Diffuser

4493

LED 1x36W 3000K 3240lm - 220/240V

Metal blanco - White metal

Difusor acrílico - Acrylic Diffuser

4082

LED 1x36W 3000K 3240lm - 220/240V

Aluminio - Aluminium

Difusor acrílico - Acrylic Diffuser



4491/4494/4087 - Plafón/Ceiling Lamp

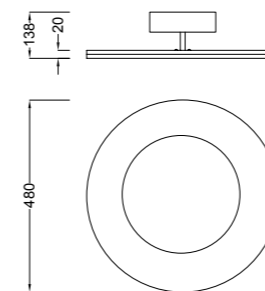

4491

LED 1x36W 3000K 3240lm - 220/240V

Metal madera - Wood metal

Difusor acrílico - Acrylic Diffuser

4494

LED 1x36W 3000K 3240lm - 220/240V

Metal blanco - White metal

Difusor acrílico - Acrylic Diffuser

4087

LED 1x36W 3000K 3240lm - 220/240V

Aluminio - Aluminium

Difusor acrílico - Acrylic Diffuser



4492/4495/4088 - Plafón/Ceiling Lamp

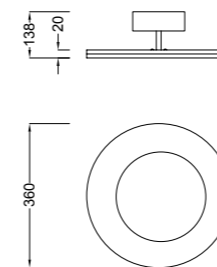

4492

LED 1x28W 3000K 1800lm - 220/240V

Metal madera - Wood metal

Difusor acrílico - Acrylic Diffuser

4495

LED 1x28W 3000K 1800lm - 220/240V

Metal blanco - White metal

Difusor acrílico - Acrylic Diffuser

4088

LED 1x28W 3000K 1800lm - 220/240V

Aluminio - Aluminium

Difusor acrílico - Acrylic Diffuser



Loewe

Design
Jose I. Ballester
2014



La colección Loewe con su combinación de líneas suaves y sencillas en sus cuerpos centrales, originales remates de cristal de burbujas, junto con sus pantallas de organza, conforman un elegante conjunto; que transmite una luz ambiental suave a las estancias. Aportando un toque distintivo y sofisticado con sus brillos y transparencias.

Loewe la componen una cuidada selección de lámparas en distintos tamaños y formatos, así como apliques de pared, sobremesas y un pie de salón de original diseño. Piezas que indistintamente se pueden adaptar al más puro ambiente de estilo clásico, o de vanguardia como especial contrapunto.

Sus acabados son en cromo brillo para sus estructuras, cristal transparente en sus remates singulares y organza blanca para sus pantallas, albergando luz E/27 en sus portalámparas.

Loewe collection, mixture of gentle and simple stroke in the central body, unique details of bubbled shaped glass with organza shade that makes an entire elegance and transmits a tender light to any spaces. It proves a distinctive and sophisticated look by its sparkle and transparencies.

Loewe is composed series of pendants with different sizes and layouts as well as wall lamp, table lamp and floor lamp that originally designed. They can be adapted to either pure classic style or avant-garde as a special accent.

Their structures are finished by polished chrome ending its unique transparent glass with white organza shade. Using E27 lampholders.



4630/4730 - Colgante/Pendant Lamp

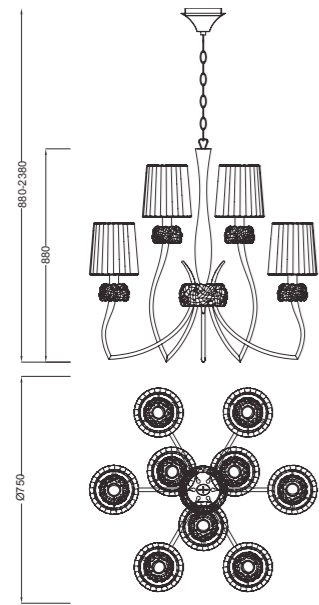

- 4630**
 E14 9x13W - 220/240V (no incl.)
 Cromo - Chrome
 Pantalla blanca - White Shade
- 4730**
 E14 9x13W - 220/240V (no incl.)
 Cuero - Antique brass
 Pantalla blanca - White Shade

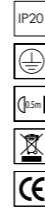

4631/4731 - Colgante/Pendant Lamp

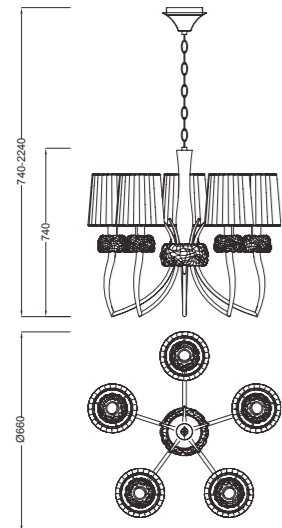

- 4631**
 E14 5x13W - 220/240V (no incl.)
 Cromo - Chrome
 Pantalla blanca - White Shade
- 4731**
 E14 5x13W - 220/240V (no incl.)
 Cuero - Antique brass
 Pantalla blanca - White Shade

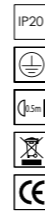

4632/4732 - Colgante/Pendant Lamp

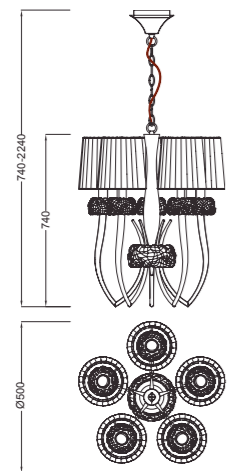

- 4632**
 E14 5x13W - 220/240V (no incl.)
 Cromo - Chrome
 Pantalla blanca - White Shade
- 4732**
 E14 5x13W - 220/240V (no incl.)
 Cuero - Antique brass
 Pantalla blanca - White Shade

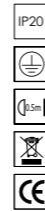

4633/4733 - Colgante/Pendant Lamp

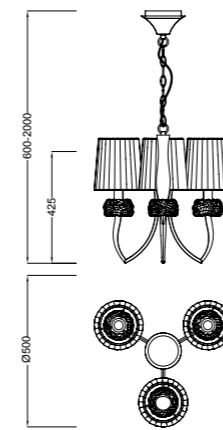

- 4633**
 E14 3x13W - 220/240V (no incl.)
 Cromo - Chrome
 Pantalla blanca - White Shade
- 4733**
 E14 3x13W - 220/240V (no incl.)
 Cuero - Antique brass
 Pantalla blanca - White Shade



4639/4739 - Colgante/Pendant Lamp

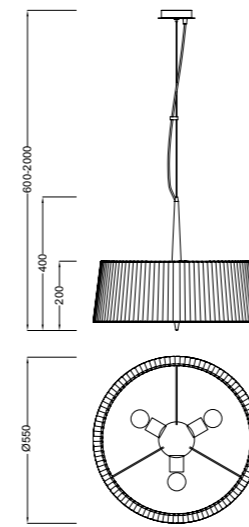

- 4639**
 E14 3x13W - 220/240V (no incl.)
 Cromo - Chrome
 Pantalla blanca - White Shade
- 4739**
 E14 3x13W - 220/240V (no incl.)
 Cuero - Antique brass
 Pantalla blanca - White Shade



4640/4740 - Plafón/Ceiling Lamp

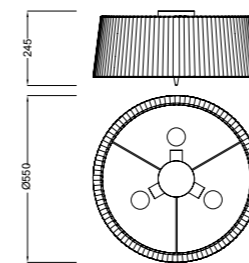

- 4640**
 E14 3x13W - 220/240V (no incl.)
 Cromo - Chrome
 Pantalla blanca - White Shade
- 4740**
 E14 3x13W - 220/240V (no incl.)
 Cuero - Antique brass
 Pantalla blanca - White Shade



4634/4734 - Aplique/Wall Lamp

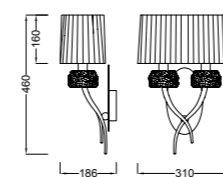

- 4634**
 E14 2x13W - 220/240V (no incl.)
 Cromo - Chrome
 Pantalla blanca - White Shade
- 4734**
 E14 2x13W - 220/240V (no incl.)
 Cuero - Antique brass
 Pantalla blanca - White Shade



4635/4735 - Aplique/Wall Lamp

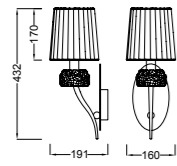

4635

E14 1x13W - 220/240V (no incl.)

Cromo - Chrome

Pantalla blanca - White Shade

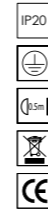

4735

E14 1x13W - 220/240V (no incl.)

Cuero - Antique brass

Pantalla blanca - White Shade



Loewe
Design
Jose I. Ballester
2014

4636/4736 - Sobremesa/Table Lamp

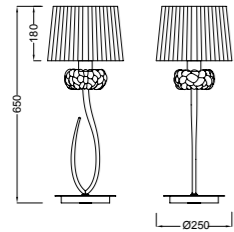

4636

E27 1x23W - 220/240V (no incl.)

Cromo - Chrome

Pantalla blanca - White Shade

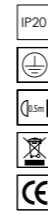

4736

E27 1x23W - 220/240V (no incl.)

Cuero - Antique brass

Pantalla blanca - White Shade

4637/4737 - Sobremesa/Table Lamp

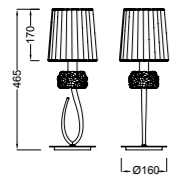

4637

E14 1x13W - 220/240V (no incl.)

Cromo - Chrome

Pantalla blanca - White Shade

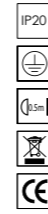

4737

E14 1x13W - 220/240V (no incl.)

Cuero - Antique brass

Pantalla blanca - White Shade

4638/4738 - Pie de Salón/Floor Lamp

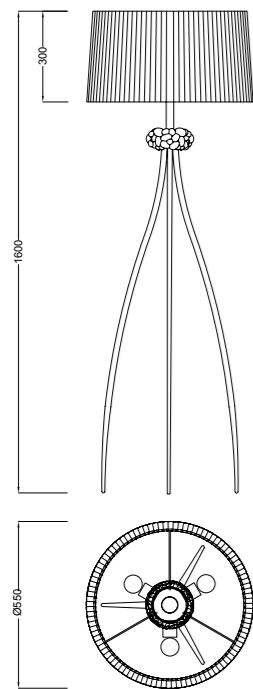

4638

E27 3x23W - 220/240V (no incl.)

Cromo - Chrome

Pantalla blanca - White Shade

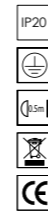

4738

E27 3x23W - 220/240V (no incl.)

Cuero - Antique brass

Pantalla blanca - White Shade



Crystal Led

Design
Mantra Team
2014







Crystal Led

Design
Mantra Team
2014

4582 - Plafón/Ceiling Lamp

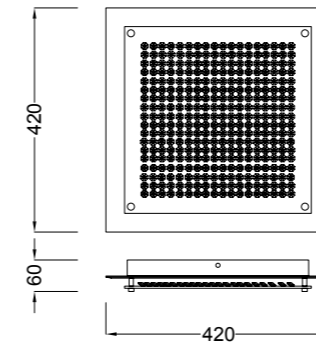

- Ⓜ LED 1x18W 3000K 1800lm - 220/240V
- Espejo - Mirror
- Cromo - Chrome



4581 - Plafón/Ceiling Lamp

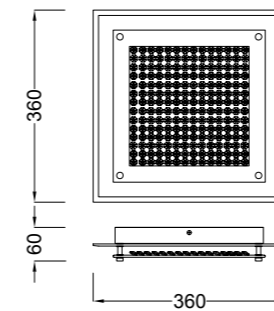

- Ⓜ LED 1x17W 3000K 1700lm - 220/240V
- Espejo - Mirror
- Cromo - Chrome



4580 - Plafón/Ceiling Lamp

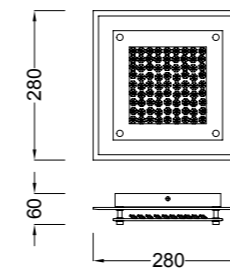

- Ⓜ LED 1x12W 3000K 1200lm - 220/240V
- Espejo - Mirror
- Cromo - Chrome





Estos plafones por su versatilidad y simplicidad se adaptan a cualquier espacio y estancia dentro de un hogar o en cualquier tipo de instalación. Realizados en los mismos acabados que las otras colecciones, se disponen en formas circulares básicas de distintos diámetros, partiendo de 25cm, pasando a 36cm Y 50cm en luz calidad y fría según re. De diámetro 77cm en luz calidad. Y otro de diámetro 55cm de ref. 3673, con diseño ligeramente diferente. El cual con su control remoto, es manipulable cambiando con el intensidades, color y su encendido-apagado.

Versatility and simplicity of these ceiling fits any space and stay at home, or any types of installation. It comes with the same finishes as other collections, arranged in basic circular shapes with different diameter from 25cm, 36cm and 50cm provided in cool or warm light. The diameter 77 cm offers warm light. Ref 3673 diameter 55cm is slightly different design which comes with remote control and can manipulate the intensity of light colour and on-off switch.

3677 - Plafón/Ceiling Lamp

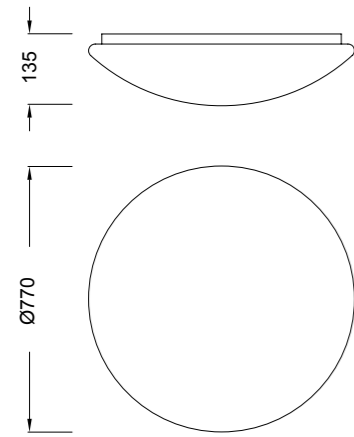

LED 1x60W 3000K 4200lm - 220/240V
 Difusor acrílico - Acrylic Diffuser

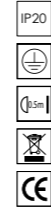

3673 - Plafón/Ceiling Lamp

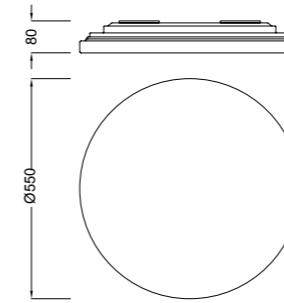

LED 1x55W 3000K-6500K 3000lm - 220/240V
 Difusor acrílico - Acrylic Diffuser



Control Remoto - Remote Control
 Luz Noche - Night Light
 Dimable (frío-calor) - Dimable (cool-warm)



Mando a distancia / Remote control

3671/3676 - Plafón/Ceiling Lamp

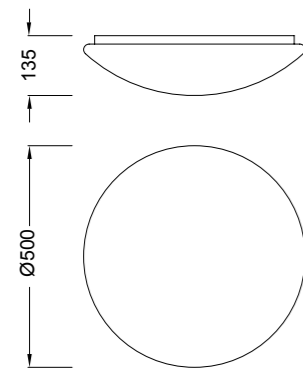

3671

LED 1x28W 3000K 2800lm - 220/240V
 Difusor acrílico - Acrylic Diffuser



3676

LED 1x28W 5500K 2800lm - 220/240V
 Difusor acrílico - Acrylic Diffuser



3670/3674 - Plafón/Ceiling Lamp

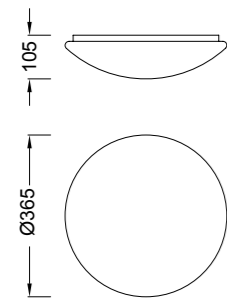

3670

LED 1x18W 3000K 1800lm - 220/240V
 Difusor acrílico - Acrylic Diffuser



3674

LED 1x18W 5500K 1800lm - 220/240V
 Difusor acrílico - Acrylic Diffuser



3672/3675 - Plafón/Ceiling Lamp

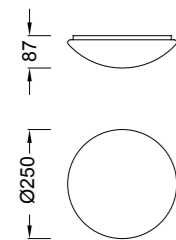

3672

LED 1x8W 3000K 800lm - 220/240V
 Difusor acrílico - Acrylic Diffuser



3675

LED 1x8W 5500K 800lm - 220/240V
 Difusor acrílico - Acrylic Diffuser



Rectangle

Design
Mantra Team
2014





Rectangle

Design
Mantra Team
2014

4671 - Plafón/Ceiling Lamp

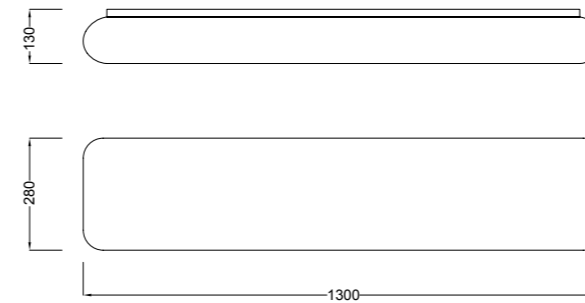

LED 1x51W 4000K 3800lm - 220/240V
Difusor acrílico - Acrylic Diffuser



4670 - Plafón/Ceiling Lamp



LED 1x25W 4000K 1900lm - 220/240V
Difusor acrílico - Acrylic Diffuser



Eos

Design
Jose I. Ballester
2014



EOS, replica las formas de las nubes y alberga una instalación alimentada por bombillas de bajo consumo, cuya luz es repartida de forma difusa y eficaz. Cuentan con el IP44 que las posibilita tanto para su instalación en interior como en el exterior bajo techado, también con una pieza convertible en lámpara de salón, suspendida con sistema de cable de acero.

EOS recreates the shapes of clouds and houses an installation supplied by low-consumption light bulbs whose light is distributed in an efficient glow. It is equipped with IP44 which facilitates its installation in an indoor or outdoor sheltered location, It is also equipped with a piece which can be converted into a living room lamp, hung with a steel cable system.





1880 - Colgante/Pendat Lamp

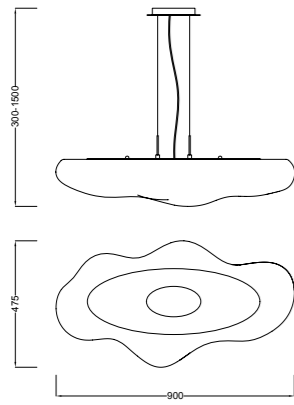

E27 6x13W - 220/240V (no incl.)
Difusor acrílico - Acrylic Diffuser

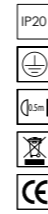

Eos
Design
Jose I. Ballester
2014

1883 - Colgante/Pendat Lamp

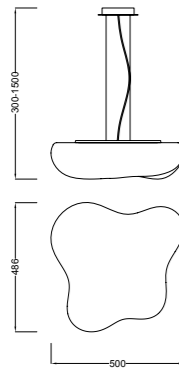

E27 4x13W - 220/240V (no incl.)
Difusor acrílico - Acrylic Diffuser

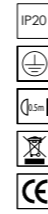

1884 - Sobremesa/Table Lamp

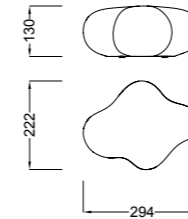

LED 1x3W 3000K 280lm - 220/240V
Difusor acrílico - Acrylic Diffuser



1881 - Plafón/Ceiling Lamp

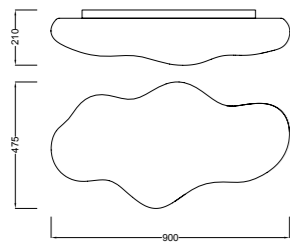

E27 6x13W - 220/240V (no incl.)
Difusor acrílico - Acrylic Diffuser

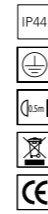

1885 - Aplique/Wall Lamp - Plafón/Ceiling Lamp

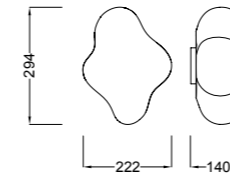

LED 1x3W 3000K 280lm - 220/240V
Difusor acrílico - Acrylic Diffuser



1882 - Plafón/Ceiling Lamp

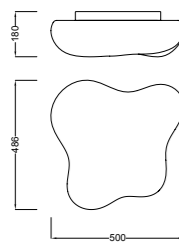

E27 4x13W - 220/240V (no incl.)
Difusor acrílico - Acrylic Diffuser

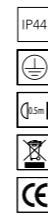

1886 - Sobremesa/Table Lamp

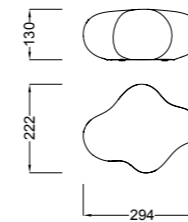

LED RGB 1x2W 90lm - 220/240V
Difusor acrílico - Acrylic Diffuser



Technical Data

Ahorrar energía no es solo ayudar a mejorar y proteger el medio ambiente, también ahorrando energía ayudamos a mejorar nuestra economía domestica, ventajas que alcanzan a nuestro bolsillo y que se traducen por sí mismas en una mejor calidad de vida. Así pues, MANTRA, consciente de aportar producto al mercado de la iluminación con este fin, el mejorar la eficiencia energética, da un pasito más al pretender que sus elementos de iluminación aporten también diseño. Sabedores que hoy por hoy todos los elementos de bajo consumo existentes en el mercado, si cada vez son más eficientes y potentes, son ante todo antiestéticos en cualquier ubicación en el hogar. Por eso hemos proyectado una línea de trabajo, posiblemente innovadora en todos los mercados, con la meta de “vestir el bajo consumo”.

Hemos reconvertido colecciones punteras de nuestro catalogo, con adaptaciones mínimas en cuanto a las proporciones de los cristales y tulipas, protagonistas en los productos, y acoplando el bajo consumo en su mínima expresión con la máxima potencia de mercado, punto por punto de luz, consiguiendo ahorros medios de consumo por elemento de un 60%.

Saving energy not only helps to improve and protect the environment but saving energy is also essential to improve our household economy, advantages which benefit our finances and help to improve the quality of our lifestyle. Hence aware of the importance of supplying such products to the lighting market with this aim, MANTRA also takes one step further to create an attractive design for its lighting elements. As everyone knows all the low-consumption lighting elements available in today's market are increasingly efficient and powerful however they have a very anti-aesthetic image when installed inside the home. Accordingly, we have designed a new product line, possibly the most innovative in all markets with the goal of “low-consumption decoration”.

We have refurbished the most popular collections of our catalogue with minimum adaptations in reference to the glass and lampshade proportions, which are major product features and have incorporated low-consumption in its minimal expression in each individual light spot with the market's maximum power; thus achieving an average consumption savings of 60% per element.

Symbols

Normativa/Normative

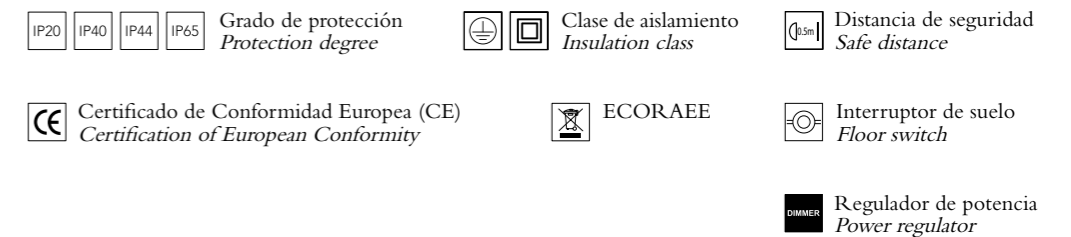

Fuentes Luminosas/Lighting Sources

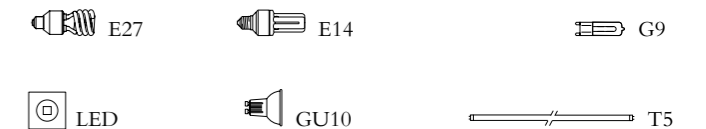

Acabados/Finishes

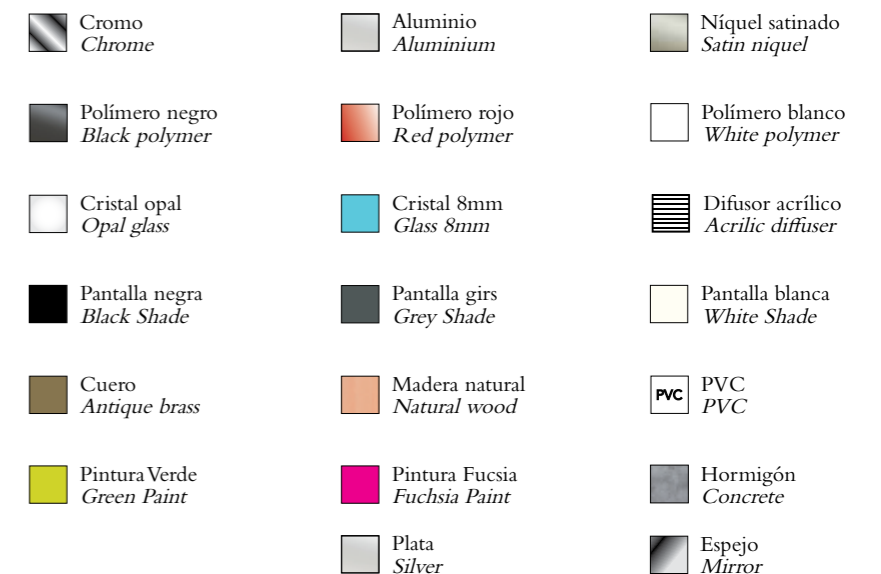

Importante/Important

Modelos a 230v 50Hz, conformidad CE.
No utilizar bombillas de potencia superior a la indicada.

*230v 50Hz models, CE approval.
Do not use lamps with higher power than indicated.*

Credits

DESIGN&ART DIRECTOR

Hugo Tejada

PHOTOGRAPHY

Jose de Les Woltes

Rafa Lanza

Vicente Moreno

Lola Alarco

THANKS TO

Kike Sorli

Santiago Sevillano

Juan Sebastian

Jose I. Ballester

Kike Sebastian

FONTYPE

Bembo Std

PAPER

Fedrigoni 170gr.

Creator Star 350gr

MADE AND PRINTED

Tempsimpresores

mAntra

Polígono Industrial los Vientos
Calle Aliso, parcela nº4
46119, Náquera, Valencia, SPAIN
T +34 96 160 99 50
F +34 96 160 99 48
mantra@mantraco.org
www.mantrailuminación.com